



# The Enterprise of the Future

Ioannis Fikouras

SAINT05

3.2.2005, Trento

## The Enterprise ten years from now

### Item-centric manufacturing

*“In the **Item-centric manufacturing** paradigm, all product and process development, as well as the configuration and control of supply chains, is product-specific and thus tailored to, but also invoked and governed by the individual product itself.”*

# Item-centric manufacturing

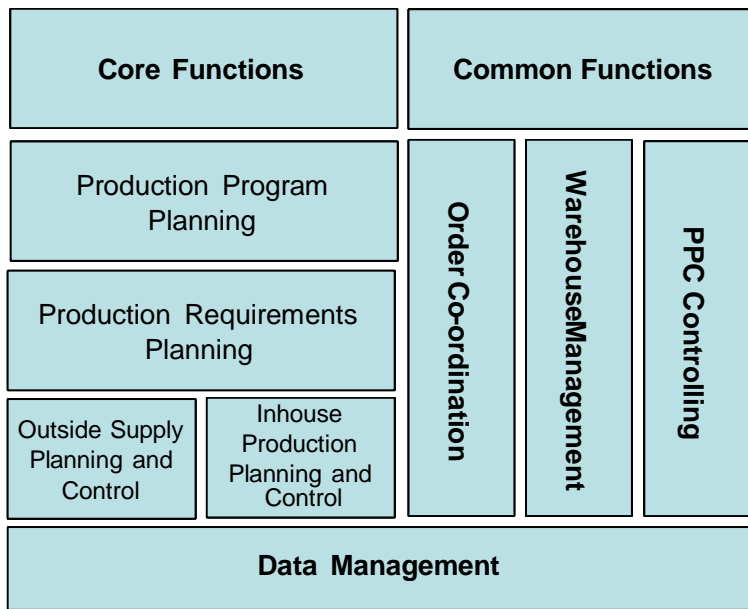

SotA PPC

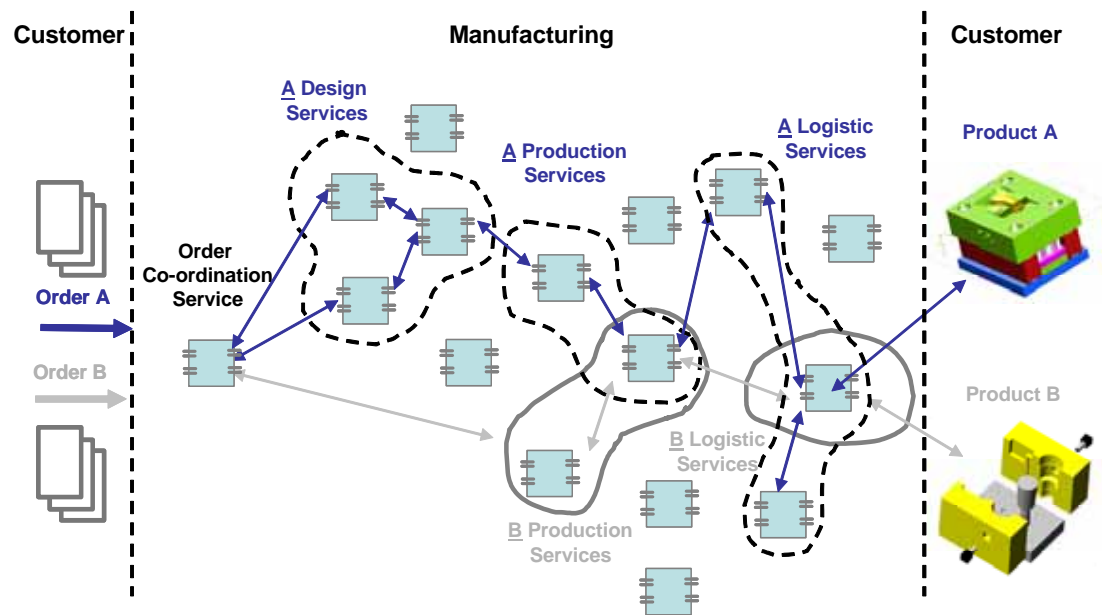

Item-centric PPC

## Multi-party Service Environments (1)

- Fully distributed **Service Oriented Computing** environment surrounding the user with **Ambient Intelligence**
- Consisting of a large number of **reusable, cooperating** and **loosely coupled** services supporting **complex configurations of actors**
- Value added services in this environment are composed out of elementary services

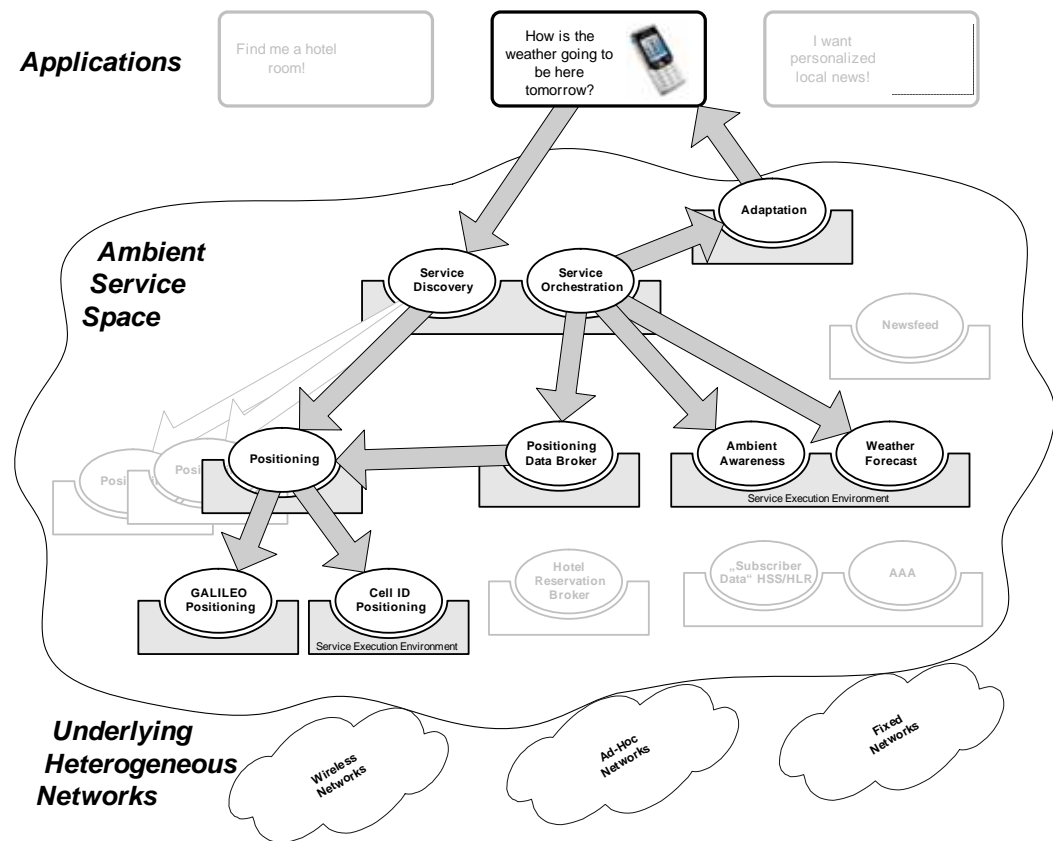

## Multi-party Service Environments (2)

- Examples include:
  - **Ambient Intelligence**
    - Context Aware/Location-Based services, mobile services
  - **Wearable Computing**
    - eHealth, eEmergency Management, eGovernment, consumer apps
  - **Autonomous mobile systems**
    - Logistics, business/leisure travellers
  - Product/Item-centric manufacturing

# Item-Centric Service Platform (1)

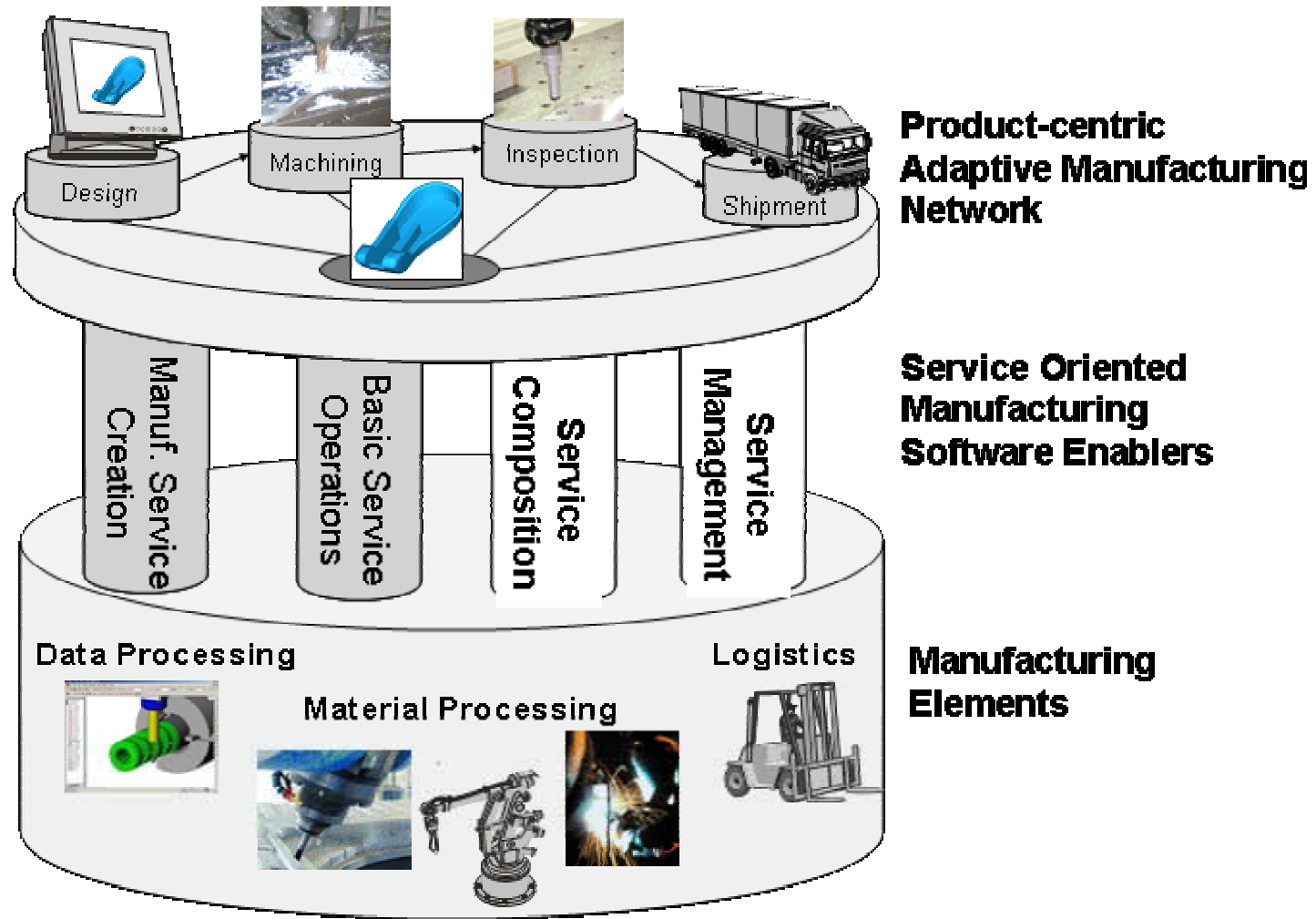

# Item-Centric Service Platform (2)

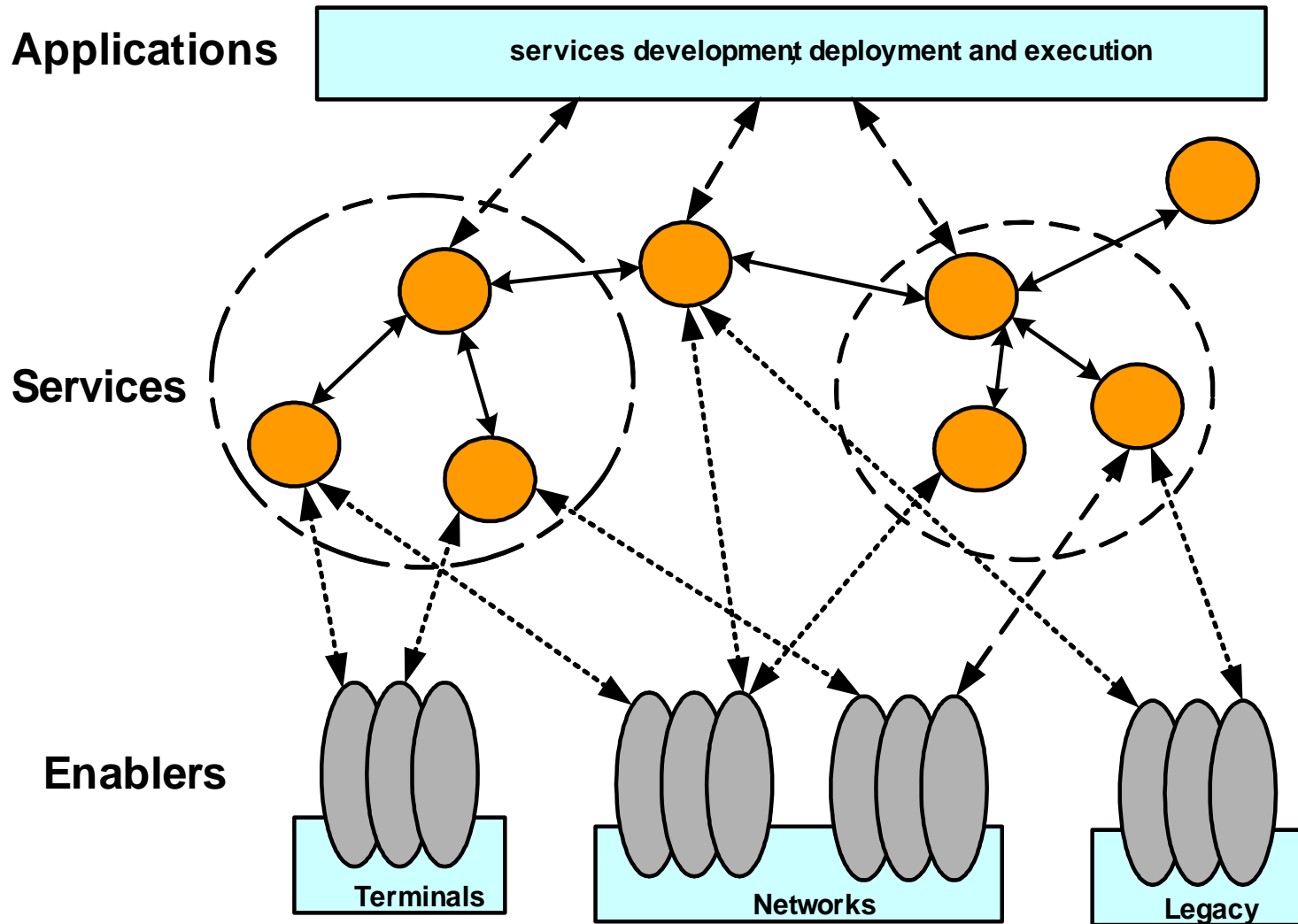

# Components of Autonomous Freight Management

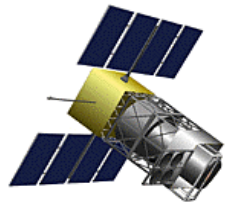

Communication over e.g. GPRS

## Tracking and tracing

- Localisation of transport system
- Localisation of freight in container

- Monitoring system
- Solution system

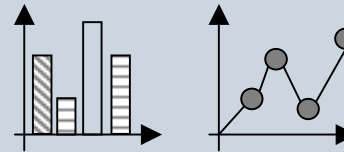

truck Y

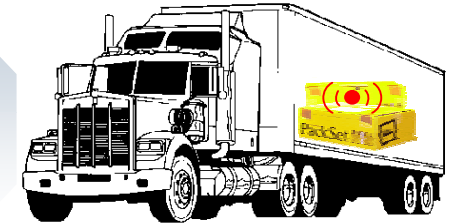

train Z

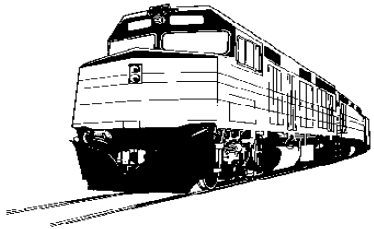

wagon load overview

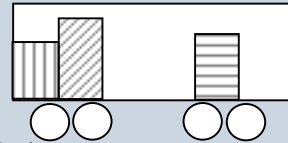

## Concept of solution generator:

- Automatic hand over of commands to robots
- Intermodal route planner
- Decision support system
- Algorithms for cost and time calculation
- Knowledge base

Monitoring of actual freight status (date, handling parameters, individual freight targets)

→ Information flow

# Intermodal traffic coordination & autonomous repacking (1)

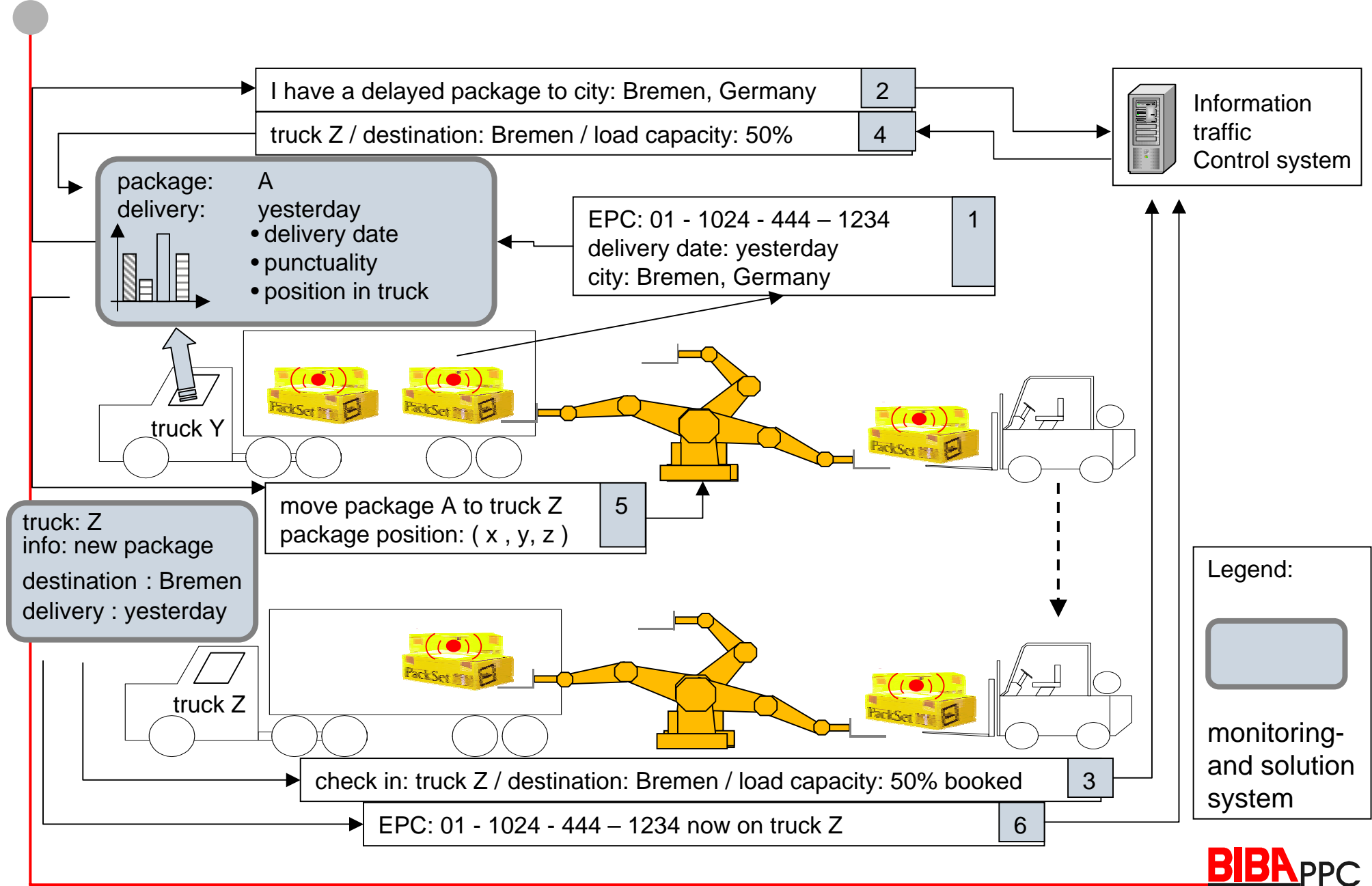

# Intermodal traffic coordination & autonomous repacking (2)



train Z

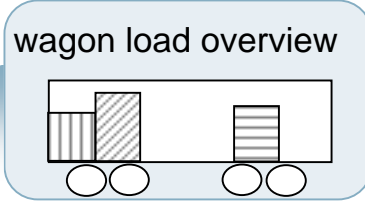

- monitoring system
- solution system
- delivery date punctuality
- position of package in truck

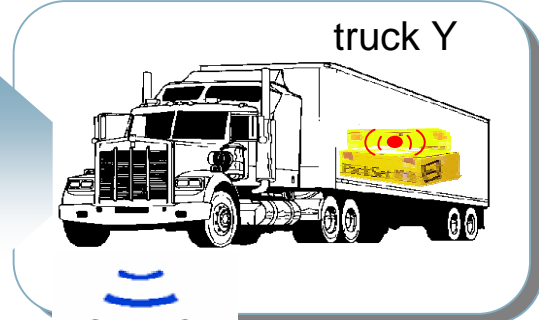

truck Y

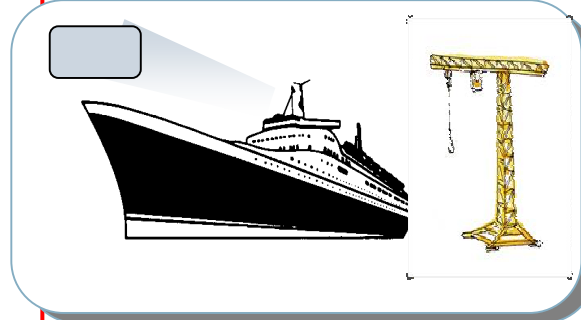

check in, load information	2	↓
transmit position of free space to load package A	5	↑
free space for package A in wagon #3, position ( x2, y2, z2 )	6	↓
prepare robot to reload package A from truck Y ( x, y, z ) to wagon #3 ( x2, y2, z2 )	7	↑

check in, load information	1	↓
train Z has free load capacity	3	↑
acceptation of train Z, position of package A ( x, y, z )	4	↓
train Z is waiting and robot is ready to reload package A	8	↑

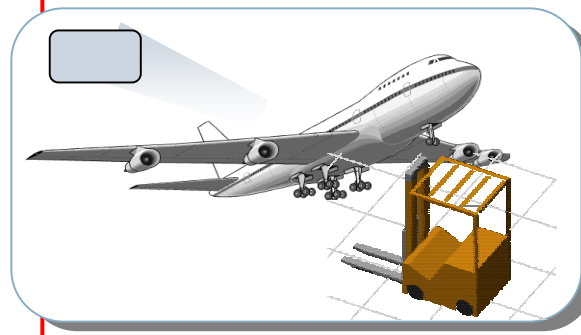

**legend**

data direction  
 wireless communication  
 monitoring system  
 repacking robot



# Research areas & issues

## Lifecycle Methodology

- Creation
  - Description, Design, Development, etc.
- Deployment
  - Registration, Rollout, etc.
- Operation
  - Discovery, Composition, Management, etc.
- Retirement/Evolution

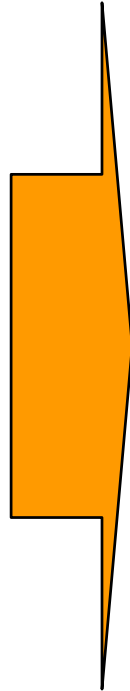

- 1. Viable shop-floor service development**
- 2. Simplifying complex service interactions**
- 3. Simplifying complex service design**
- 4. Efficient management and operation of multi-party services**

● **Thank you!**

Item-centric manufacturing & logistics is a promising vision for European Enterprise ten years from now

Ioannis Fikouras

[fks@biba.uni-bremen.de](mailto:fks@biba.uni-bremen.de)

**BIBA**

<http://www.biba.uni-bremen.de>

**BIBA**PPC